

XEV

# INNOVATION MEETS INSPIRATION



# YOYO PRO



**Brand New**  
★ 2024 ★

## Fashionable and Exquisite Urban Mobility with Personality

Diverse, urban-inspired color palette to choose from.

Futuristic design and elegant interior.

Light construction for effortless driving.

Smart touch screen and one-click remote control, easy to use.

Rapid Battery-Swapping system to eliminate range anxiety.

Customizable 3D printing side blades for endless personalization.

# Specifications



Length	2530mm
Width	1500mm
Height	1570mm
Wheelbase	1680mm
Range	150km

## Zero Range Anxiety



Battery Swapping : 3 minutes battery exchange at your nearest Swapping Station.



Plug In Charging : Using a standard socket or our dedicated wall box.  
Charging Time : 3-4 hours ( from 0-100%)

# Colors



# Xpression

## BE UNIQUE

Experience the ultimate personalization with the YOYO's customizable side blade, tailored to suit your individual taste. Embrace your creativity by selecting your favourite style and redefine your urban mobility companion in a way that truly reflects your personality. With the YOYO, everyday driving transforms into an enjoyable and distinct experience, making your journeys both fun and unique.

## BE INNOVATIVE

XEV has pioneered advanced 3D printing technology that opens up a world of possibilities for personalization by offering a wide array of choices and stylish options. Revolutionizing urban mobility, offering quick and precise solutions using cutting-edge 3D printing techniques.

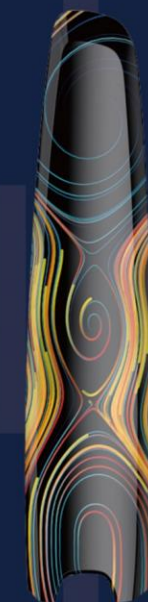
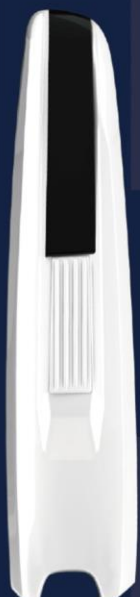

## Art Institution Cooperation



UAAD is a global emerging on-line art platform in New York. XEV cooperates with UAAD to enhance artistic diversity, offering the YOYO blades in even more stylish choices and transforming the blades into artistic and collectible pieces.

# Simple, Streamlined, and Futuristic 3D Design.

- Frameless door
- Panoramic sunroof
- Integrated LED head lamp
- Unique side blades



YOYO combines a panoramic sunroof, frameless doors, and distinctive 3D lights. The clever use of glass and steel creates overlapping and intersecting elements throughout, achieving a perfect balance between classic and advanced aesthetics.



# Interior Where Style, Comfort, and Technology Unite.

- Stylish color scheme
- Multifunctional leather steering wheel
- Perforated leather sports style seats
- Flexible and abundant storage space
- Spacious trunk



YOYO is thoughtfully designed with environmentally-friendly materials, ensuring a comfortable and welcoming space for all passengers.



# Intelligence

- 10.25 inch smart touchscreen
- Smart phone mirror display
- Bluetooth music/phone
- APP remote control
- Key remote control



Air-condition Control

Windows and Doors Control



*New,  
Customer  
focused,  
Freedom,  
Accessibility.*

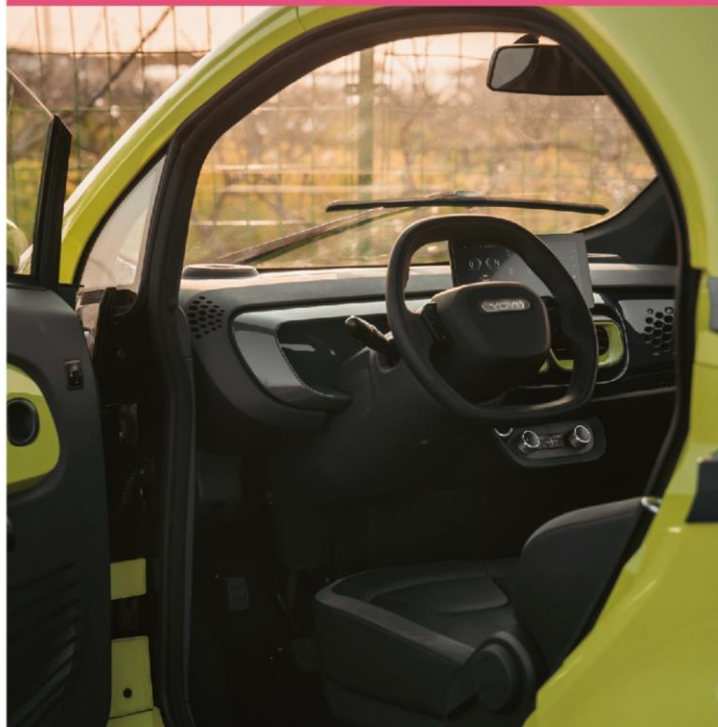

YOYO stands out with its striking color combinations, complemented by the convenience of a 10.25 inch smart touchscreen and app control, creating a high-quality interior that reflects your personal style.

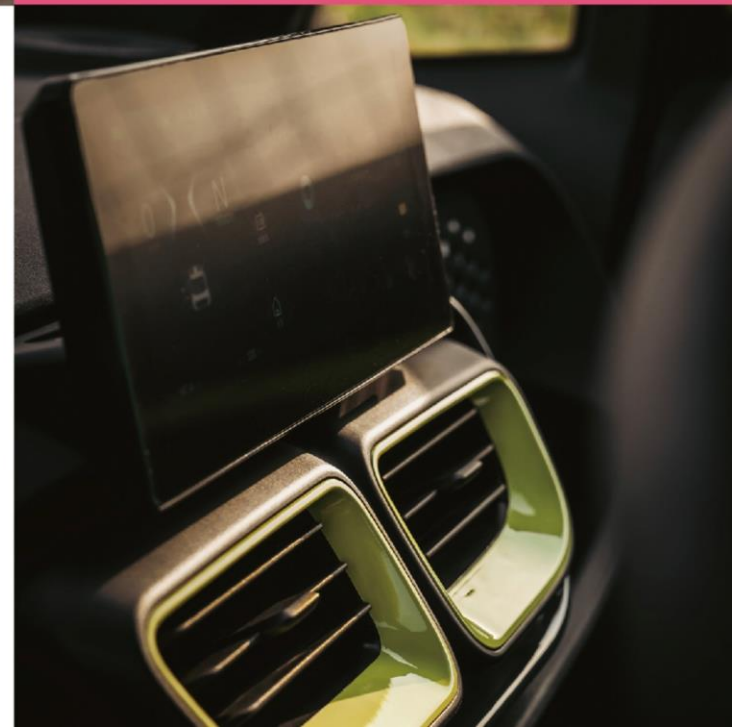

# Safety and Performance

- Integrated high-strength cage body
- McPherson independent suspension
- Rear engine rear drive
- Intelligent battery detection
- Battery protection system

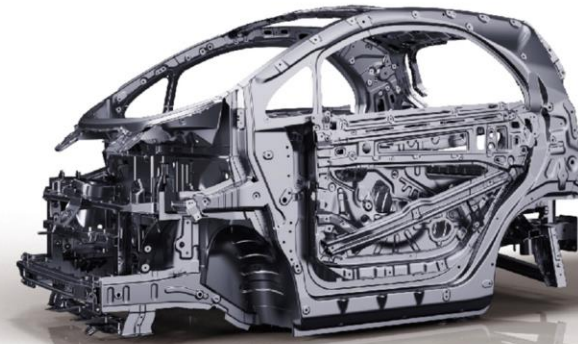

## Battery

YOYO has both heating function and intelligent insulation function. A battery safety protection module exists, which can easily detect leakage, short-circuit. XEV YOYO cares your safety.

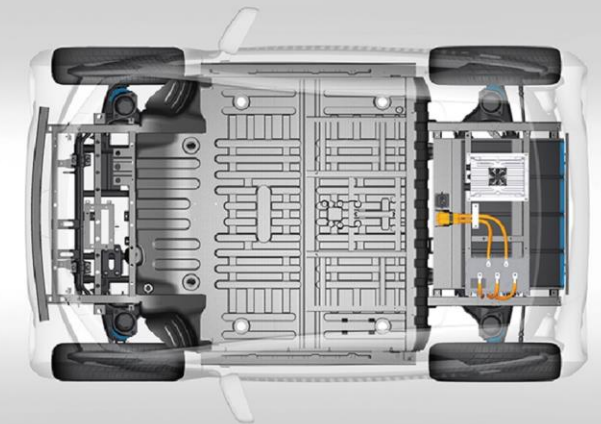

## More Features

- Electric brake force distribution,EBD
- Hill-start assist control(anti-slipping),HAC
- Anti pinch window
- D/S-gear single pedal energy recovery
- Peristaltic starting



## "Light" Battery

Battery can be replaced within 3 minutes.



## "Light" Installation

Easy construction and tooling with an area of less than 1.5 square meters, ordinary commercial power grid can be operated.

# Battery Swapping Service



# »»»» Energy Network

YOYO, with two doors and two seats, has a flexible body. The unique and portable model benefits over 50 million clients, urban mobility and large-scale EV applications in Europe.



# »»»» XEV plans to launch more than 7000 sites across Europe by 2025



## In Italy

We operate more than 100 sites in 11 cities with a population of over 200,000.

## In Germany, Spain, France and Turkey

We have more than 100 sites in about 15 major cities.

# »»»» A Global EV&Technology Company

XEV is characterized by intelligent battery swapping service and world's first mass-produced car models with 3D printing customized service, providing excellent experience and environment-friendly intelligent urban mobility for users around the world.

XEV is dedicated to the carbon neutrality and sustainable development of cities, convenient and interesting mobility for people, and cultural communication among users.



XEV currently has distribution channels in 20 countries and a sales network covering 113 cities.

# Our History

**2018**

XEV was founded in Turin, Italy.



**2019**

Launched XEV's first urban mobility EV YOYO, which debuted at Turin Motor Show in the same year.



**2021**

YOYO's sale began in May, 2021 in Europe and its cumulative delivery number has exceeded 10,000 by 2022.



**2020**

YOYO began its mass production in 2020, and cooperated with powerful partners in different fields in Europe including autonomous driving and car sharing, exploring more environment-friendly solutions of urban mobility.



**2022**

Started a strategic partnership with ENI to carry out the operation of the battery swapping network in Europe.



YOYO debuted at the Turin Auto Show and received great interest



YOYO was shortlisted in the 2022 ADI Design Award



YOYO was the first self-owned brand to become the designated service car of the FI-Milan Station in Italy



# Intelligently Manufacturing

Professional dedicated team management, grasping the manufacturing core.

Built in Accordance with XEV Quality System  
Advanced Manufacturing Technological Process  
with **European Standard Certification**

IATF 16949

ISO 9001



Covering an area of  
**427,000**  
square meters

Annual capacity of  
**150,000**  
units



Four craft workshops  
**Automation  
Production**

Takt Time  
**30 JPH** (max)



# YOYO

## URBAN MOBILITY REVOLUTION

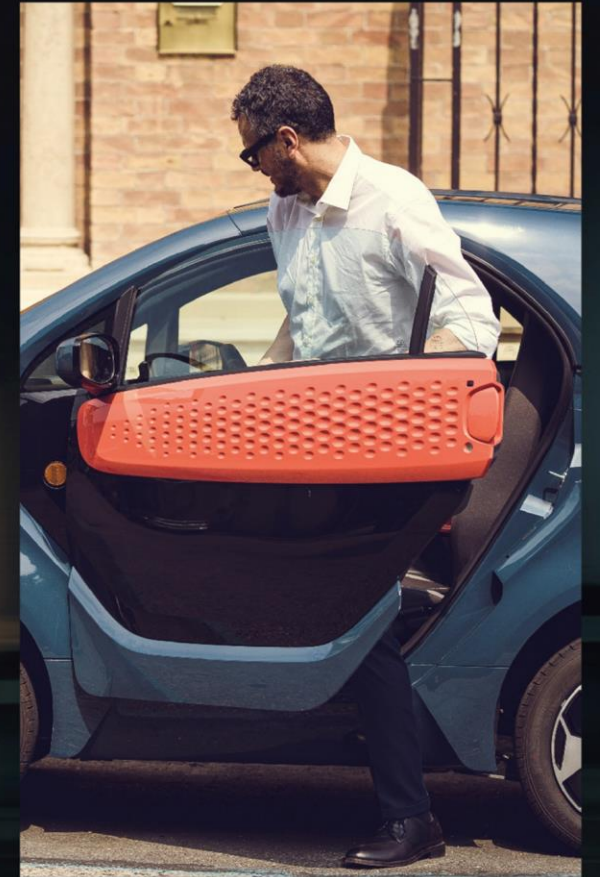

Instagram



Facebook



XEV

[www.xev-global.com](http://www.xev-global.com)

XEV reserves the right of final interpretation for all the information.  
All specifications are subject to actual products for sale.